

Quiz – Chapter 19

- When we apply reverse bias to a P-N junction at less than the avalanche voltage, the junction
 - does not conduct.
 - conducts intermittently.
 - conducts fairly well.
 - conducts very well.
- Which, if any, of the following statements is false?
 - Some audio enthusiasts think that power amplifiers made with vacuum tubes sound better than power amplifiers made with semiconductor devices.
 - Tubes are physically larger than transistors that do the same things.
 - Transistors need more voltage, in general, than vacuum tubes to operate properly.
 - All of the above statements are true.
- When we dope a semiconductor with an acceptor impurity, we get
 - E type material.
 - N type material.
 - P type material.
 - H type material.
- When we dope a semiconductor with an acceptor impurity, that material ends up with a surplus of
 - protons.
 - neutrons.
 - electrons.
 - holes.
- Pure silicon is
 - a compound.
 - an element.
 - a mixture.
 - a liquid.
- When we forward-bias a P-N junction, it fails to conduct
 - unless the junction has enough capacitance.
 - if the applied voltage is less than the forward breakover voltage.
 - if the applied voltage exceeds the avalanche voltage.
 - unless the voltage remains constant.
- Donor impurities have an inherent excess of
 - neutrons.
 - protons.
 - electrons.
 - holes.
- Imagine a “bucket” containing more electrons than holes. The net electrical charge of the “bucket’s” contents is
 - positive.
 - negative.
 - zero.
 - impossible to determine.
- We apply DC reverse bias to a P-N junction, but it’s not enough to cause avalanche effect. Then we double the voltage, but it still doesn’t cause an avalanche effect. What happens to the capacitance at the depletion region?
 - It stays the same.

- (b) It increases.
- (c) It decreases.
- (d) None of the above; a depletion region has inductance, not capacitance.

10. We apply DC reverse bias to a P-N junction, but it's not enough to cause avalanche effect. Then we increase the voltage past the point where avalanche effect occurs. What happens?

- (a) The junction conducts.
- (b) The depletion region expands to take up the whole diode.
- (c) The junction's reactance increases.
- (d) The diode burns out.

11. Gallium arsenide is

- (a) a compound.
- (b) a liquid.
- (c) an element.
- (d) a mixture.

12. Which of the following materials makes the best choice for a photocell?

- (a) Bismuth
- (b) Indium
- (c) Aluminum
- (d) Selenium

13. Semiconductor manufacturers can make pure germanium into an N type semiconductor material by

- (a) adding a donor impurity.
- (b) adding an acceptor impurity.
- (c) applying a negative charge.
- (d) None of the above; they can't!

14. Which of the following things can happen when we dope a semiconductor material?

- (a) We get a pure chemical element.
- (b) Current flows mostly as holes.
- (c) We get a conductor.
- (d) We get a dielectric.

Schematic 19-1

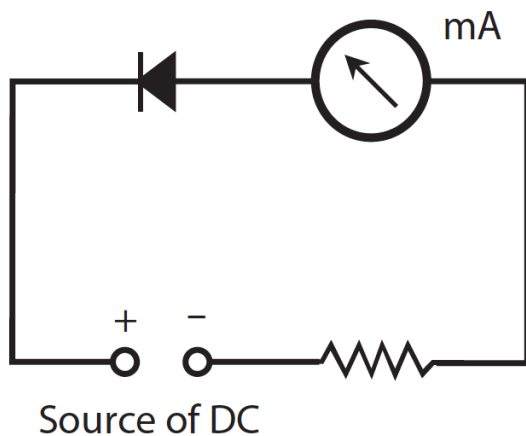

15. In the circuit of Schematic 19-1, the milliammeter (mA) indicates no current. By examining the polarities of the diode and the DC source, we can see that the diode is

- (a) reverse-biased beyond the avalanche voltage.
- (b) reverse-biased below the avalanche voltage.
- (c) forward-biased beyond the forward breakover voltage.
- (d) forward-biased at less than the forward breakover voltage.

Schematic 19-2

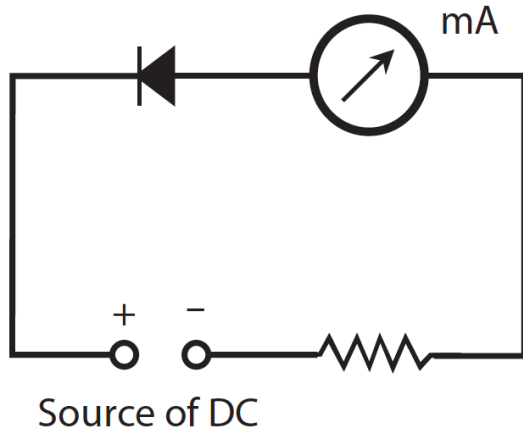

16. In the circuit of Schematic 19-2, the milliammeter (mA) indicates significant current. By examining the polarities of the diode and the DC source, we can see that the diode is

- (a) reverse-biased beyond the avalanche voltage.
- (b) reverse-biased below the avalanche voltage.
- (c) forward-biased beyond the forward breakover voltage.
- (d) forward-biased below the forward breakover voltage.

17. Charge carriers move faster through some semiconductors than others. In general, as the charge-carrier speed increases, so does the maximum

- (a) speed at which a device made with that substance can operate.
- (b) voltage that the substance can withstand.
- (c) current that the substance can handle.
- (d) resistance of a component made with that substance.

18. In a P-N junction forward-biased beyond the forward breakover voltage, the junction

- (a) is surrounded by a zone devoid of charge carriers.
- (b) acts like a capacitor.
- (c) does not conduct current.
- (d) None of the above

19. Which of the following things commonly serves as a charge carrier in a semiconductor?

- (a) An atomic nucleus
- (b) A proton
- (c) A neutron
- (d) An electron

20. Fill in the blank to make the following statement true: "In a semiconductor material, _____ account(s) for most of the current."

- (a) minority carriers
- (b) majority carriers
- (c) electrons
- (d) holes

Answers:

1. a, 2. c, 3. c, 4. d, 5. b, 6. b, 7. c, 8. b, 9. c, 10. a, 11. a, 12. d, 13. a, 14. b, 15. b, 16. a, 17. a, 18. d, 19. d, 20. b

Quiz – Chapter 20

1. Which of the following diode types can we use to produce ultra-high frequency (UHF) or microwave signals?
(a) Gunn
(b) Tunnel
(c) IMPATT
(d) All of the above
2. We'll find an LED in
(a) a microwave oscillator.
(b) an optoisolator.
(c) a rectifier.
(d) a voltage regulator.

Figure 20-1.

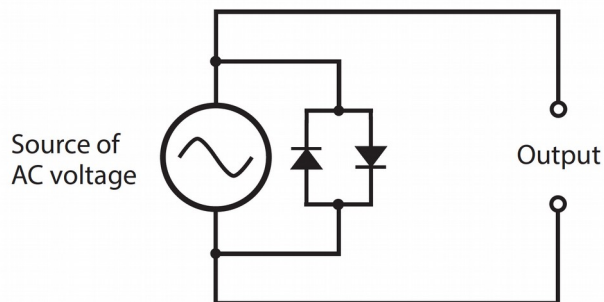

3. We can connect two diodes, as shown in Fig. 20-1, to obtain
(a) oscillation.
(b) demodulation.
(c) amplification.
(d) clipping.
4. In a crystal-set radio receiver, the diode should have the smallest possible
(a) junction capacitance.
(b) forward-breakover voltage.
(c) avalanche voltage.
(d) reverse bias.
5. Diodes can work as frequency multipliers because diodes
(a) are nonlinear devices.
(b) can demodulate signals.
(c) require no external power.
(d) All of the above
6. What do we call a condition in which the current through a component goes down as the voltage across it goes up?
(a) Nothing! It can't happen, so it has no name.
(b) Transconductance
(c) Negative resistance

(d) Current inversion

7. We input signals at 0.700 MHz and 1.300 MHz to a diode-based mixer. We get output at

- (a) 0.500 MHz.
- (b) 1.00 MHz.
- (c) 0.600 MHz.
- (d) All of the above

8. Which of the following diode types would we use in a circuit designed to measure the brilliance of a visible light source?

- (a) A rectifier diode
- (b) A photodiode
- (c) A Zener diode
- (d) An RF diode

9. Which of the following diode types would we use in a crystal set?

- (a) A rectifier diode
- (b) A photodiode
- (c) A Zener diode
- (d) An RF diode

10. When we apply negative voltage to a diode's anode and positive voltage to the cathode, we sometimes get

- (a) avalanche breakdown.
- (b) forward bias.
- (c) junction depletion.
- (d) forward breakover.

Figure 20-2

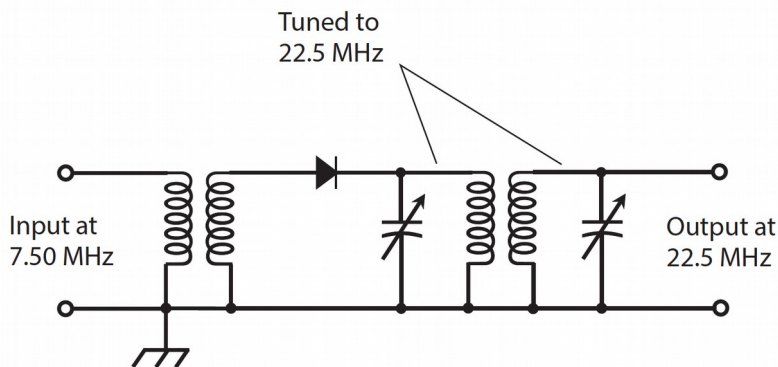

11. In the circuit of Fig. 20-2, the diode's nonlinearity allows it to function as a frequency multiplier. Nonlinearity also allows a diode to function as

- (a) a microwave oscillator.
- (b) a signal mixer.
- (c) an optoisolator.
- (d) a PV cell.

12. Which of the following statements applies to the diode in a voltage-controlled oscillator (VCO)?

- (a) It requires high voltage.
- (b) It demodulates the signals.
- (c) It operates in a state of reverse bias.
- (d) It has low (almost no) resistance.

13. We'll usually find a varactor diode in
- a voltage regulator.
 - a rectifier.
 - an optoisolator.
 - a VCO.
14. We input a pure sine-wave signal to a circuit with a diode that introduces nonlinearity. Which of the following statements holds true for the output?
- It contains numerous signals at whole-number multiples (1, 2, 3, 4, etc.) of the input signal frequency.
 - It contains numerous signals at whole-number fractions of the input signal frequency (1, 1/2, 1/3, 1/4, etc.).
 - It contains a signal at one and only one frequency: that of the input signal.
 - We need more information to answer this question.
15. The maximum voltage that a solar panel assembled with silicon PV cells can produce depends on
- the number of cells in series, or in series-connected sets of parallel-connected cells.
 - the number of cells in parallel, or in parallel-connected sets of series-connected cells.
 - the surface area of the entire panel, regardless of how the cells are connected.
 - Any of the above
16. The visible light emitted by an LED occurs as
- a result of avalanche effect.
 - the reverse-bias voltage decreases.
 - electrons lose energy in atoms.
 - the PN junction gets hot.

Figure 20-3

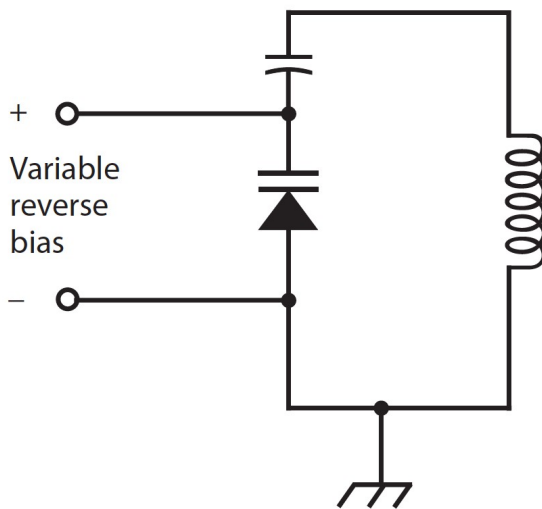

17. What happens to the LC resonant frequency as we increase the reverse-bias voltage across the varactor in the circuit of Fig. 20-3, assuming that avalanche breakdown never occurs?
- It fluctuates.
 - It goes up.
 - It goes down.
 - Nothing.
18. What would happen if the fixed capacitor in the circuit of Fig. 20-3 shorted out?
- The circuit would no longer amplify.
 - Excessive current would flow through the varactor.

- (c) The output voltage would become unstable.
- (d) The inductor would short out the source of reverse bias meant for the varactor.

19. Which of the following diode types is manufactured for minimum junction capacitance so it can work as an RF switch?

- (a) An IMPATT diode
- (b) A “cat’s whisker”
- (c) A PIN diode
- (d) A Gunn diode

20. In which of the following devices does a photodiode serve an essential function?

- (a) A rectifier
- (b) An optoisolator
- (c) A frequency multiplier
- (d) A VCO

Answers:

1. d, 2. b, 3. d, 4. a, 5. a, 6. c, 7. c, 8. b, 9. d, 10. a, 11. b, 12. c, 13. d, 14. a, 15. a, 16. c, 17. b, 18. d, 19. c, 20. b

Quiz – Chapter 21.

1. In a common-base transistor circuit, the output and input waves differ in phase by

- (a) 1/4 of a cycle.
- (b) 1/3 of a cycle.
- (c) 1/2 of a cycle.
- (d) None of the above

2. Which of the following circuit configurations do engineers sometimes use in place of conventional wirewound transformers to match a high input impedance to a low output impedance?

- (a) Common emitter
- (b) Common base
- (c) Common collector
- (d) Any of the above

3. Current will never flow in the B-C junction of a grounded-emitter bipolar transistor when we

- (a) reverse-bias the E-B junction and apply no input signal.
- (b) forward-bias the E-B junction beyond forward breakover and apply no input signal.
- (c) zero-bias the E-B junction and apply a strong input signal.
- (d) forward-bias the E-B junction beyond forward breakover and apply a weak input signal.

Schematic 21-1.

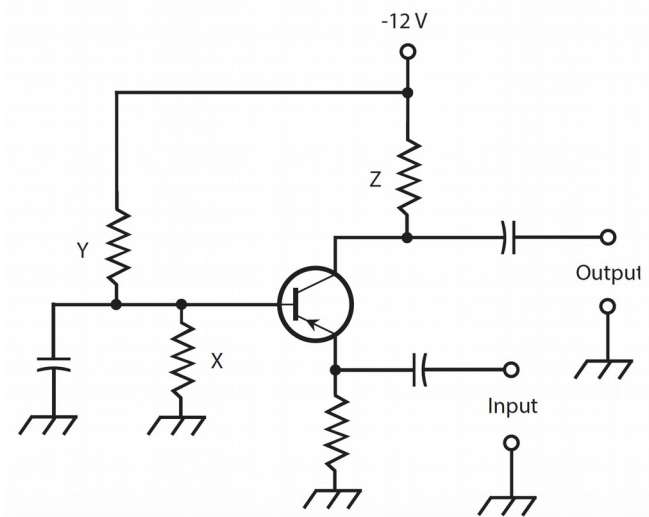

4. Schematic 21-1 illustrates a bipolar transistor and several other components in
- a common-emitter configuration.
 - an emitter-follower configuration.
 - a common-base configuration.
 - a common-collector configuration.
5. What, if any, major errors exist in the circuit of Fig. 21-12?
- Nothing is wrong, assuming that we choose the component values properly.
 - We should use an NPN transistor, not a PNP transistor.
 - The power-supply polarity at the collector should be positive, not negative.
 - We should transpose the input and output terminals.
6. In the circuit of Schematic 21-1, what purpose does component X serve?
- It keeps the signal from “shorting out” to ground.
 - It helps to establish the proper bias at the base.
 - It ensures that the circuit won’t break into oscillation.
 - It keeps the base at signal ground.
7. In the circuit of Schematic 21-1, what purpose does component Y serve?
- It keeps the input isolated from the output.
 - It keeps the output signal from “shorting out” through the power supply.
 - It ensures that the circuit won’t break into oscillation.
 - It helps to establish the proper bias at the base.
8. In the circuit of Schematic 21-1, what purpose does component Z serve?
- It helps the circuit to function as an oscillator by providing feedback.
 - It keeps the output signal from “shorting out” through the power supply.
 - It helps to establish the proper bias at the base.
 - It ensures that the output wave remains in phase opposition with respect to the input wave.
9. In an emitter-follower circuit, we apply the input signal between the
- collector and ground.
 - emitter and collector.
 - base and ground.
 - base and collector.
10. In the dual-diode model of a PNP transistor, the base corresponds to
- the point at which the cathodes meet.

- (b) the point at which the cathode of one diode meets the anode of the other.
- (c) the point at which the anodes meet.
- (d) either of the anodes.

11. Suppose that we encounter a schematic diagram of a complicated circuit that uses bipolar transistors. For some reason, the draftsman didn't put the arrows inside the transistor symbols. Can we nevertheless differentiate between NPN and PNP devices? If so, how?

- (a) No, we can't.
- (b) Yes, we can. For a PNP device, the applied DC collector voltage is always positive with respect to the emitter voltage, while for an NPN device, the applied DC collector voltage is always negative with respect to the emitter voltage.
- (c) Yes, we can. For a PNP device, the applied DC collector voltage is always negative with respect to the emitter voltage, while for an NPN device, the applied DC collector voltage is always positive with respect to the emitter voltage.
- (d) Yes, we can. For a PNP device, the E-B junction is always forward-biased, while for an NPN device, the E-B junction is always reverse-biased.

12. With no signal input, a properly connected common-emitter NPN bipolar transistor would have the highest value of I_c when

- (a) we forward-bias the E-B junction considerably beyond forward breakover.
- (b) we connect the base directly to the negative power-supply terminal.
- (c) we reverse-bias the E-B junction.
- (d) we connect the base directly to electrical ground.

13. Suppose that for a certain transistor at a specific constant frequency, we find that the alpha equals 0.9315. What's the beta?

- (a) We can't determine it because our figure for the alpha makes no sense. We must have made a mistake when we determined the alpha!
- (b) 13.60
- (c) 0.4823
- (d) 1.075

14. Suppose that for a certain transistor at a certain frequency, we find that the beta equals 0.5572. What's the alpha?

- (a) We can't determine it because our figure for the beta makes no sense. We must have made a mistake when we determined the beta!
- (b) 1.258
- (c) 0.3578
- (d) 1.795

15. Suppose that for a certain transistor at a certain frequency, we find that the alpha equals exactly 1.00. What's the beta?

- (a) We can't define it.
- (b) 0.333
- (c) 0.500
- (d) 1.00

16. In a common-emitter circuit, we normally take the output from the

- (a) emitter.
- (b) base.
- (c) collector.
- (d) More than one of the above

Schematic 21-2.

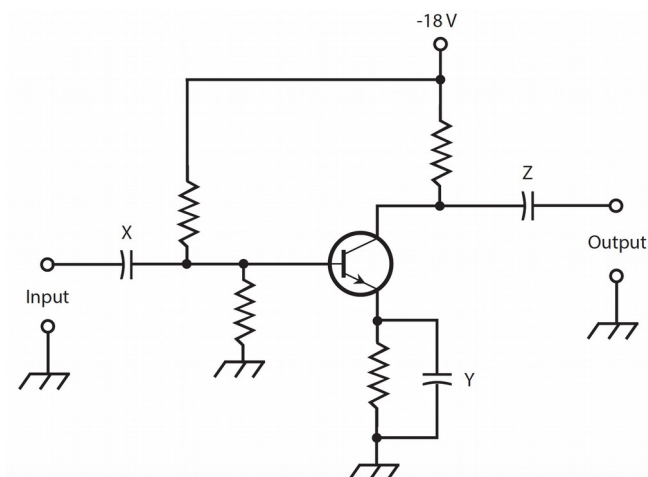

17. What major error exists in the circuit of Schematic 21-2?
- The power supply voltage is too high for any bipolar transistor to handle.
 - We should use an NPN transistor, not a PNP transistor.
 - The power-supply polarity at the collector should be positive, not negative.
 - We should transpose the input and output terminals.
18. In the circuit of Schematic 21-2, what purpose does component X serve?
- It keeps the signal from “shorting out” through the emitter.
 - It helps to establish the proper bias at the collector.
 - It keeps the signal from “feeding back” into the input device.
 - It blocks DC to or from the external input device, while letting the AC signal pass.
19. In the circuit of Schematic 21-2, what purpose does component Y serve?
- It keeps the input isolated from the output.
 - It keeps the input signal from “shorting out” through the power supply.
 - It keeps the emitter at signal ground, while allowing a DC voltage to exist there.
 - It helps to establish the proper bias at the base.
20. In the circuit of Schematic 21-2, what purpose does component Z serve?
- It keeps the circuit from breaking into oscillation.
 - It blocks DC to or from the external output device while letting the AC signal pass.
 - It matches the transistor’s impedance to the impedance of the external output device, or load.
 - It ensures that the output wave remains in phase with the input wave.

Answers:

1. d, 2. c, 3. a, 4. c, 5. a, 6. b, 7. d, 8. b, 9. c, 10. a, 11. c, 12. a, 13. b, 14. c, 15. a, 16. c, 17. c, 18. d, 19. c, 20. b

Quiz - Chapter 22

- In a JFET, current through the channel varies because of the effects of
 - a magnetic field.
 - an electric field.
 - leakage current.
 - avalanche current.
- In a P- channel JFET, assuming that the drain voltage remains constant, pinchoff occurs when we place the gate at a
 - tiny negative voltage with respect to the source.
 - significant negative voltage with respect to the source.
 - tiny positive voltage with respect to the source.

(d) significant positive voltage with respect to the source.

3. When we bias a JFET at the point on its I_D versus V_G curve at which we can expect to derive the most amplification, the value of $d I_D / d V_G$, representing the slope of the curve at that point, is
(a) zero (“running horizontally”) with no signal input, and the curve appears as a straight line near the point.

(b) positive (“ramping upward to the right”) with no signal input, and the curve appears as a straight line near the point.

(c) negative (“ramping downward to the right”) with no signal input, and the curve bends downward near the point.

(d) positive (“ramping upward to the right”) with no signal input, and the curve bends downward near the point.

4. Under no-signal conditions, a zero-biased enhancement-mode MOSFET operates in a state of

(a) pinchoff.

(b) avalanche breakdown.

(c) saturation.

(d) forward breakover.

Figure 22-1.

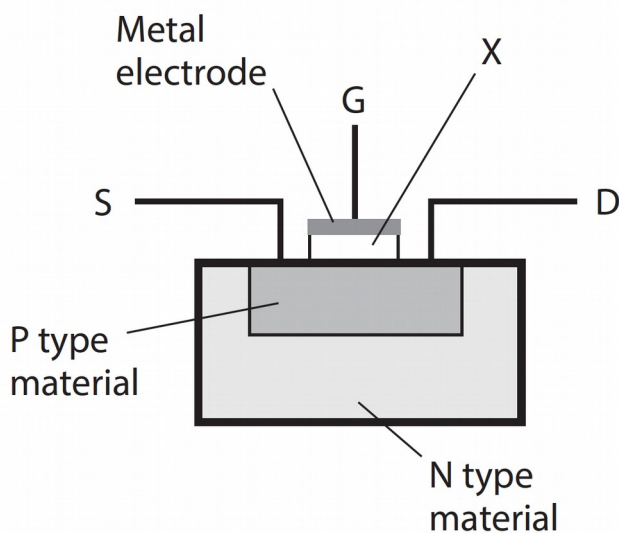

5. Figure 22-1 is a simplified cutaway diagram of

(a) a P- channel JFET.

(b) an N- channel JFET.

(c) a P- channel MOSFET.

(d) an N- channel MOSFET.

6. In Fig. 22-1, the item marked X constitutes

(a) a thin wafer of N type material.

(b) a thin layer of dielectric material.

(c) a thin layer of highly conductive material.

(d) a P-N junction.

7. A bipolar transistor might work better than a JFET or MOSFET when we want an amplifier to

(a) have good weak-signal performance.

(b) have low input impedance.

(c) produce high transconductance.

(d) draw the most possible power from the input signal source.

8. A properly operating MOSFET presents a G-S resistance
- (a) of practically zero.
 - (b) lower than that of a JFET.
 - (c) comparable to that of a similar-sized capacitor.
 - (d) lower than that of a bipolar transistor.
9. In a FET of any kind, we generally don't want to see DC flow between the
- (a) source and the drain.
 - (b) source and the channel.
 - (c) drain and the channel.
 - (d) gate and the channel.
10. In a MOSFET, the majority carriers are electrons
- (a) if the device has an N-type channel.
 - (b) when forward breakover occurs.
 - (c) when avalanche breakdown occurs.
 - (d) under no circumstances.
11. Which of the following circuits produces an output signal wave that's precisely in phase with the input signal wave?
- (a) The common-gate circuit
 - (b) The common-drain circuit
 - (c) The source follower
 - (d) All of the above
12. A small electrostatic discharge, such as might appear on a technician's hands, can easily destroy a MOSFET by
- (a) fusing the source to the drain.
 - (b) eliminating the charge carriers in the channel.
 - (c) destroying the insulating properties of the dielectric.
 - (d) causing forward breakover at the gate-drain junction.
13. A significant difference between MOSFETs and JFETs is the fact that
- (a) JFETs usually have lower input impedances.
 - (b) JFETs are less electrically rugged.
 - (c) JFETs are physically larger.
 - (d) JFETs require far higher operating voltages.
14. We can recognize a depletion-mode MOSFET (as opposed to an enhancement-mode MOSFET) in schematic diagrams by the presence of
- (a) an arrow pointing inward.
 - (b) a broken vertical line inside the circle.
 - (c) an arrow pointing outward.
 - (d) a solid vertical line inside the circle.
15. In a source follower, from which two points do we obtain the output signal?
- (a) The drain and ground
 - (b) The drain and gate
 - (c) The gate and source
 - (d) The source and ground

Figure 22-2.

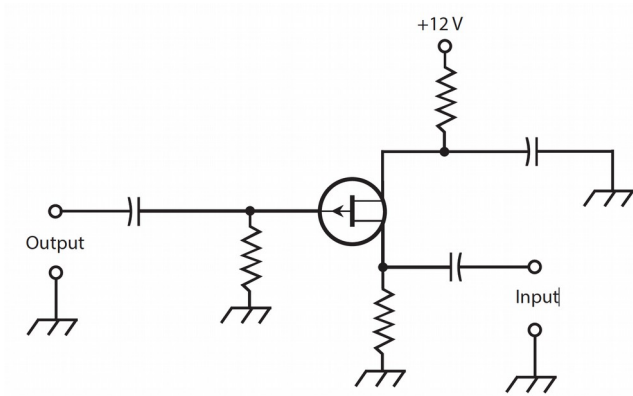

16. Figure 22-2 illustrates a source follower with two major errors. To correct one of the errors, we must

- transpose the input and output terminals.
- replace the JFET with a depletion-mode MOSFET.
- replace the JFET with an enhancement-mode MOSFET.
- replace the gate resistor with a capacitor.

17. To correct the second error in Fig. 22-2, we must

- connect the drain directly to the positive DC voltage source by replacing the drain resistor with a length of wire.
- replace the gate capacitor with a resistor.
- replace the source capacitor with a resistor.
- reverse the DC power-supply polarity.

Figure 22-3

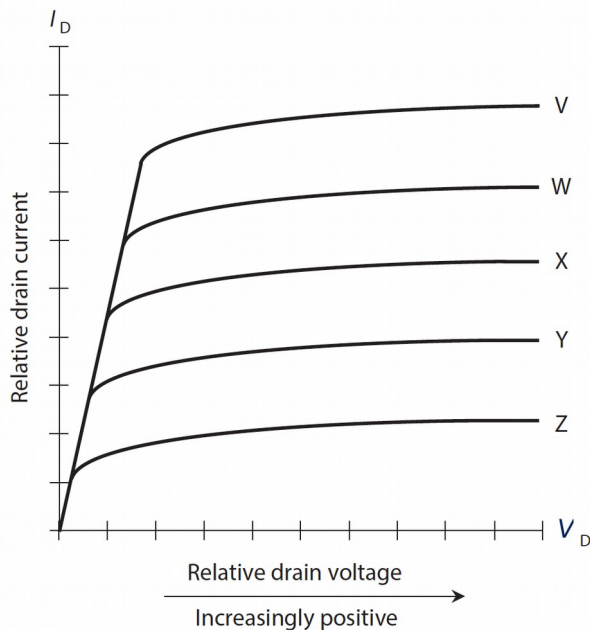

18. Figure 22-3 illustrates a family of characteristic curves for a hypothetical N- channel, depletion-mode MOSFET. The curves V through Z portray the behavior of the device for various

- DC source voltages under no-signal conditions.
- AC input signal voltages.
- DC gate voltages under no-signal conditions.

(d) AC output signal voltages.

19. What can we say about the relative voltages for curves V through Z in Fig. 22-3?

Remember, we're dealing with an N- channel, depletion-mode MOSFET.

(a) They're DC voltages that get progressively less positive (or more negative) as we proceed down from V to Z.

(b) They're DC voltages that get progressively less negative (or more positive) as we proceed down from V to Z.

(c) They're AC voltages whose peak-to-peak values increase as we proceed down from V to Z.

(d) They're AC voltages whose peak-to-peak values decrease as we proceed down from V to Z.

20. Notice how all the curves in Fig. 22-3 tend to "level off" as we move toward the right in the coordinate grid. What does the "leveling-off" tell us about the general behavior of this particular N- channel, depletion-mode MOSFET?

(a) As we increase the positive DC drain voltage under no-signal conditions, the drain current increases slowly at first, then more and more rapidly.

(b) As we increase the positive DC drain voltage under no-signal conditions, the drain current increases rapidly at first, then more and more slowly.

(c) As we increase the peak-to-peak AC input signal voltage, the drain current increases slowly at first, then more and more rapidly.

(d) As we derive increasing peak-to-peak AC output signal voltage from the device, the drain current increases rapidly at first, then more and more slowly.

Answers:

1. b, 2. d, 3. b, 4. a, 5. c, 6. b, 7. b, 8. c, 9. d, 10. a, 11. d, 12. c, 13. a, 14. d, 15. d, 16. a, 17. d, 18. c, 19. a, 20. b

Quiz – Chapter 23

1. We can keep an op amp from producing too much gain or minimize the risk of unwanted oscillation in an op amp by means of

(a) positive feedback.

(b) negative feedback.

(c) inductive feedback.

(d) capacitive feedback.

2. a CMOS chip contains

(a) n-channel MOSFETs.

(b) p-channel MOSFETs.

(c) both n-channel and p-channel MOSFETs.

(d) bipolar transistors

3. If we want to build an analog audio amplifier for driving a headset or a small speaker, we might use

(a) a Memory IC.

(b) a linear IC.

(c) an op-amp.

(d) a CMOS IC.

4. Which, if any, of the following component types is least practical for direct fabrication on an IC chip?

(a) Resistor

(b) Capacitor

(c) Inductor

(d) Transistor

5. Which of the following IC types would we most likely use to build a circuit that takes a pure sine-wave input and produces a pure sine-wave output at the same frequency but lagging the input by 90° ?
- (a) Op amp
 - (b) CMOS
 - (c) Memory IC
 - (d) Digital IC
6. Fill in the blank to make the following sentence true: "In a RAM chip, data is stored as _____."
- (a) sine waves at various frequencies
 - (b) currents through tiny resistors
 - (c) magnetic fields in tiny inductors
 - (d) charges in tiny capacitors
7. Which of the following characteristics usually represents an advantage of a discrete component circuit over the use of an equivalent IC?
- (a) Higher power-handling capacity
 - (b) Streamlined maintenance
 - (c) Improved reliability
 - (d) All of the above
8. In which of the following types of memory chip can we overwrite data fastest?
- (a) Flash memory
 - (b) Hard Disk
 - (c) EEPROM
 - (d) RAM
9. Which of the following characteristics do we commonly see in CMOS chips?
- (a) Sensitivity to damage by electrostatic discharge
 - (b) Suitability for analog use only
 - (c) High current demand
 - (d) Extremely limited speed
10. An integrator IC shifts the phase of a pure AC sine-wave input signal by
- (a) 180° .
 - (b) 90° .
 - (c) 45° .
 - (d) an amount that depends on the frequency.
11. With respect to memory, which of the following expressions tells us that the data remains intact even if we remove all external sources of power?
- (a) Saturated
 - (b) Static
 - (c) Dynamic
 - (d) Nonvolatile
12. In terms of the maximum number of transistors on a single chip, how many orders of magnitude larger is LSI than VLSI?
- (a) One
 - (b) Two
 - (c) Three
 - (d) The premise of the question is wrong. The maximum number of transistors on an LSI chip is smaller than the maximum number of transistors on a VLSI chip.
13. In which of the following devices would you likely find an IC serving as the main

component?

- (a) The filter in a high-voltage power supply
- (b) The final amplifier in a TV broadcast transmitter
- (c) An electronic calculator
- (d) All of the above

14. Which of these statements about ICs is true?

- (a) IC-based designs are generally more reliable than equivalents using discrete components.
- (b) A solution using ICs is always more expensive than equivalents using discrete components.
- (c) ICs are inherently less reliable than discrete designs
- (d) Capacitors cannot be integrated into ICs.

15. The component density specification for an IC gives us a good idea of the

- (a) average diameter of the elements in the chip.
- (b) average surface area of the elements in the chip.
- (c) average mass-to-volume ratio of the elements in the chip.
- (d) total number of individual elements in the chip.

16. If we supply a differentiator IC with a constant input of +2 V DC, we observe an output of

- (a) +2 V DC.
- (b) 0 V DC, that is, nothing at all.
- (c) -2 V DC.
- (d) pure, sine-wave AC.

17. Which of the following is an op-amp NOT suited to?

- (a) Buffering high impedance outputs to low impedance
- (b) Power amplification
- (c) Pre-amplification of audio signals
- (d) Integration

18. Which of these types of IC could be used with an analog temperature sensor as part of a thermostat? c

- (a) a timer IC
- (b) a memory IC
- (c) a comparator IC
- (d) a voltage regulator IC

19. Which of the following statements about op-amps is false?

- (a) op-amps must always have positive and negative power supplies
- (b) op-amps
- (c) ICs are available containing more than one op-amp
- (d) op-amps are an example of an analog IC

20. A differentiator IC shifts the phase of a pure AC sine-wave input signal by

- (a) 180°.
- (b) 90°.
- (c) 45°.
- (d) An amount that depends on the frequency.

Answers:

1. b, 2. c, 3. b, 4. c, 5. a, 6. d, 7. a, 8. d, 9. a, 10. b, 11. d, 12. d, 13. c, 14. a, 15. d, 16. b, 17. b, 18. c, 19. a, 20. b

Quiz – Chapter 24

1. Voltage regulation can be accomplished by means of a Zener diode across a power supply's filter output, reverse-biased, along with a series-connected

- (a) voltage-limiting capacitor.
- (b) power-limiting diode.
- (c) current-limiting resistor.
- (d) All of the above

2. Suppose that we apply a 60-Hz pure AC sine wave of 330 V pk-pk (peak-to-peak), having no DC component, to the input of a full-wave bridge rectifier circuit. The effective DC output voltage is

- (a) more than 330 V.
- (b) exactly 330 V.
- (c) slightly less than 330 V.
- (d) considerably less than 330 V.

3. The output of a rectifier circuit with excellent filtering compares favorably to the output of

- (a) a DC battery of the same voltage.
- (b) an AC transformer with the same RMS secondary voltage.
- (c) a DC battery with half the voltage.
- (d) an AC transformer with the same peak-to-peak secondary voltage.

4. Which of the following components is not always required in a power supply designed to produce 24 V pure DC output with 117 V RMS AC input?

- (a) A transformer
- (b) A rectifier circuit
- (c) A filtering circuit
- (d) A voltage-regulator circuit

5. Suppose that you see a fuse with a straight wire and a spring inside. You can assume that this fuse

- (a) has a low current rating.
- (b) has a high current rating.
- (c) is a slow-blow type.
- (d) is a quick-break type.

6. Transients can result from

- (a) intermittent diode failure in a power supply.
- (b) localized thundershowers.
- (c) improper installation of filter capacitors.
- (d) the use of improperly rated Zener diodes.

7. Suppose that a fuse blows out repeatedly. We get tired of the inconvenience, and replace the fuse with a unit having a higher current rating. This action can give rise to all of the following dangers except one. Which one?

- (a) Serious damage (or further damage) might occur to electronic components in the supply.
- (b) Personnel who work with equipment connected to the supply might receive deadly electrical shocks.
- (c) One or more of the components in the supply might catch on fire.
- (d) Voltage or current spikes might occur on the power lines outside the house.

8. Which of the following characteristics represents an advantage of a half-wave rectifier circuit in certain applications?

- (a) It uses the whole transformer secondary for the full AC input cycle.
- (b) The pulsating DC output is easier to filter than the output of a full-wave circuit.
- (c) It costs less than other rectifier types because it uses fewer components.
- (d) It offers superior voltage regulation compared to all other rectifier types.

9. If we want to build a power supply designed to provide well-filtered, high-voltage DC at low current levels without the need for good regulation, the cheapest option would be to use a

- (a) harmonic-generator circuit.

- (b) full-wave, center-tap circuit.
- (c) full-wave bridge circuit.
- (d) voltage-doubler circuit.

10. An advantage of a buck convertor over a linear voltage regulator is:

- (a) fewer components are needed
- (b) better efficiency
- (c) no capacitors are needed
- (d) no inductors are needed

11. Referring to Figure 24-10 in the book, what is the purpose of L1?

- (a) to temporarily store energy for release into the load
- (b) to filter the output voltage
- (c) to boost the input voltage
- (d) all of the above

12. Referring to Figure 24-10 in the book, what is the purpose of D1?

- (a) to 'snub' voltage spikes
- (b) to rectify the AC input
- (c) to provide a path for current to flow from the inductor through the load
- (d) to protect C1 from over-voltage

13. Referring to Figure 24-11 in the book, what is the purpose of IC1's EN pin?

- (a) to enable the IC when connected to IN
- (b) to enable the IC when grounded
- (c) to provide a second ground connection to the IC
- (d) to measure the output voltage so that it can be regulated

14. When might it be better to use a linear voltage regulator rather than a buck converter?

- (a) When energy efficiency is paramount
- (b) When the circuit needs to run cool
- (c) In high power applications
- (d) In low power applications

15. Modern 'wall-wart' SMPSs are light-weight because: b

- (a) They use air-core transformers rather than iron-core
- (b) The high power low frequency transformer of a conventional power supply is not needed
- (c) They are only good for very low current operation
- (d) They are filled with helium

16. A linear voltage regulator IC looks a lot like

- (a) a large resistor.
- (b) an electrolytic capacitor.
- (c) a power transistor.
- (d) a Zener diode.

17. If we use a full-wave bridge rectifier circuit with an AC input of 12 V RMS, each diode should have a PIV rating of at least

- (a) 17 PIV.
- (b) 25 PIV.
- (c) 34 PIV.
- (d) 50 PIV.

18. If we use a half-wave rectifier circuit with an AC input of 12 V RMS, the PIV that actually appears across the diode in the reverse direction is approximately

- (a) 17 V PIV.
- (b) 25 V PIV.

- (c) 34 V PIV.
- (d) 50 V PIV.

19. If we use a half-wave rectifier circuit with an AC input of 12 V RMS, the diode should have a PIV rating of at least

- (a) 17 PIV.
- (b) 25 PIV.
- (c) 34 PIV.
- (d) 50 PIV.

20. An SMPS contains, among other components,

- (a) a chopper.
- (b) an optoisolator.
- (c) rectifiers.
- (d) All of the above

Answers:

1. c, 2. d, 3. a, 4. d, 5. c, 6. b, 7. d, 8. c, 9. d, 10. b, 11. a, 12. c, 13. b, 14. d, 15. b, 16. c, 17. b, 18. c, 19. d, 20. d

Quiz – Chapter 25 – Amplifiers

1. Which of the following is an advantage of class B push-pull amplifier designs over single-sided class B? d

- (a) Fewer components
- (b) Transistors do not need to be matched
- (c) The level of even harmonics will be higher
- (d) Lower distortion

2. If we increase the RMS voltage of a signal by a factor of 10,000 across a pure, constant resistance, we observe a signal gain of

- (a) 100 dB.
- (b) 80 dB.
- (c) 40 dB.
- (d) 20 dB.

3. Suppose that we supply 1.00 W of RMS input to an amplifier that provides a power gain of 33.0 dB. What's the output, assuming that no reactance exists in the system?

- (a) 2.00 kW RMS
- (b) 330 W RMS
- (c) 200 W RMS
- (d) 50.0 W RMS

4. Imagine that we apply a signal of 30 V RMS to the primary winding of a perfectly efficient impedance-matching transformer (it dissipates no power as heat in its core or windings), obtaining 10 V RMS across the secondary. Also suppose that no reactance exists in the circuits connected to the primary and secondary. This transformer technically introduces

- (a) a voltage loss of approximately 9.5 dB, which we can also call a voltage gain of approximately -9.5 dB.
- (b) a voltage gain of approximately 4.8 dB, which we can also call a voltage loss of approximately -4.8 dB.
- (c) a current loss of approximately 9.5 dB, which we can also call a current gain of approximately -9.5 dB.
- (d) a current gain of approximately 4.8 dB, which we can also call a current loss of approximately -4.8 dB.

5. Which of the following components would we most likely choose if we want to allow DC to pass from one circuit point to another, but we want to keep high-frequency AC signals from

following the same path?

- (a) A varactor
- (b) A blocking capacitor
- (c) An RF choke
- (d) A Gunn diode

6. Referring to Figure 25-7 in the book, what is the purpose of C1?

- (a) To remove filter out high frequency noise
- (b) To smooth the DC supply to the amplifier
- (c) To provide a ready reservoir of energy to power the speaker
- (d) None of the above

7. Referring to Figure 25-7 in the book, what is the purpose of R1?

- (a) A volume control
- (b) To reduce the input signal by a fixed amount
- (c) To provide an audio tone control
- (d) To protect the input to the audio amplifier from over-current

8. Which of the following is NOT necessarily an advantage of using an audio amplifier IC?

- (a) Lower distortion
- (b) Lower component count
- (c) Simplified design
- (d) Lower cost

9. In which of the following bipolar-transistor amplifier types does collector current flow for less than half of the signal cycle?

- (a) Class-C
- (b) Class-B
- (c) Class-AB₂
- (d) Class-AB₁

10. When designing and testing a tuned class-B push-pull RF power amplifier, we must

- (a) bias the transistors to ensure that collector or drain current flows in both devices during the entire AC input signal cycle.
- (b) select the capacitors so as to allow the system to work over a wide range of frequencies without adjustment.
- (c) set the output tuned circuit to resonate at an even harmonic of the input frequency.
- (d) select two bipolar or field-effect transistors whose characteristics are as nearly identical as possible.

11. Which of the following statements about using a class D audio amplifier IC is FALSE? b

- (a) class D amplifiers are generally higher efficiency than linear amplifiers
- (b) class D amplifiers generally have lower distortion than linear amplifiers
- (c) class D amplifiers generally get hotter than linear amplifiers
- (d) class D amplifiers generally cost a lot more than linear amplifiers

12. Which FET amplifier type introduces little or no distortion into the AC signal wave, with drain current during the entire signal cycle?

- (a) Class A
- (b) Class AB₁ or AB₂
- (c) Class B
- (d) Class C

13. We can make a class-B amplifier linear for the AC signal waveform by

- (a) minimizing the output impedance.
- (b) biasing the transistor considerably past cutoff or pinchoff.
- (c) connecting two transistors in a push-pull arrangement.

(d) no known means.

14. What is the advantage of using a low impedance loudspeaker?

- (a) The loudspeaker uses less wire
- (b) The loudspeaker will have less distortion
- (c) The loudspeaker will operate at greater efficiency
- (d) More power can be delivered to the loudspeaker for the same amplifier output voltage amplitude.

15. Suppose that a certain FET-based RF PA operates with an efficiency of 60%. We measure the DC drain input power as 90 W. We can have confidence that the RF signal output power is

- (a) 54 W
- (b) 90 W
- (c) 150 W
- (d) impossible to determine without more information.

Schematic 25-1.

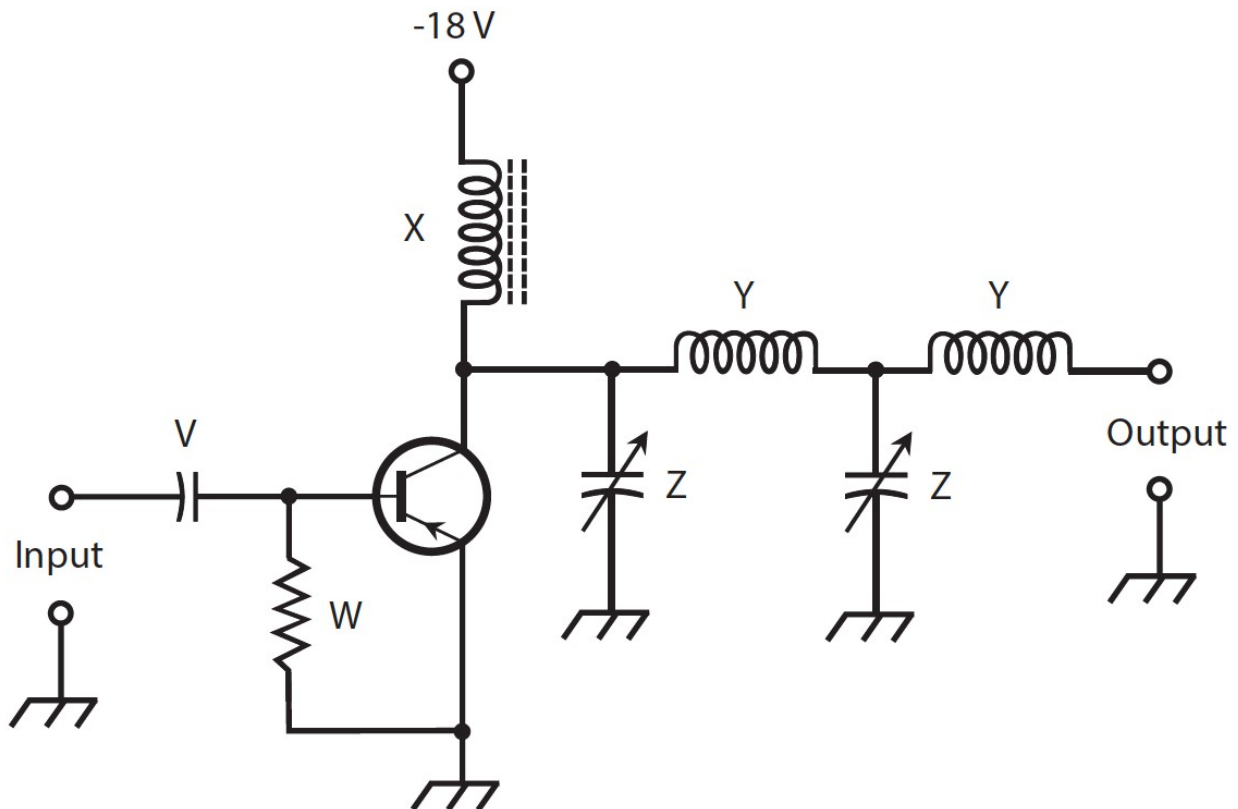

16. Schematic 25-1 illustrates a generic tuned, class-B RF PA. According to the knowledge of bipolar transistor

circuits that we've gained so far in this course, we can surmise that the capacitor labeled V

- (a) provides proper bias for the transistor.
- (b) allows the AC input signal to enter but provides DC isolation.
- (c) determines the resonant frequency of the input circuit.
- (d) keeps the signal from shorting through the power supply.

17. According to the knowledge of bipolar-transistor circuits that we've gained so far in this course, we can surmise that the resistor labeled W in Schematic 25-1

- (a) provides proper bias for the transistor.

- (b) allows the AC input signal to enter but provides DC isolation.
- (c) determines the resonant frequency of the input circuit.
- (d) keeps the signal from shorting through the power supply.

18. According to the knowledge of bipolar-transistor circuits that we've gained so far in this course, we can surmise that the RF choke labeled X in Schematic 25-1

- (a) prevents excessive current from flowing in the collector.
- (b) allows the AC output signal to leave but provides DC isolation.
- (c) determines the resonant frequency of the output circuit.
- (d) keeps the signal from shorting through the power supply.

19. According to the knowledge of bipolar-transistor circuits that we've gained so far in this course, we can surmise that the inductors labeled Y in Schematic 25-1

- (a) help to optimize the signal transfer to the output.
- (b) ensure that the output signal remains in phase with the input signal.
- (c) provide enough feedback to keep the circuit from oscillating.
- (d) keep the transistor from operating in a state of overdrive.

20. According to the knowledge of bipolar-transistor circuits that we've gained so far in this course, we can surmise that the capacitors labeled Z in Schematic 25-1

- (a) help to optimize the signal transfer to the output.
- (b) ensure that the output signal remains in phase with the input signal.
- (c) provide enough feedback to keep the circuit from oscillating.
- (d) keep the transistor from operating in a state of overdrive.

Answers:

1. d, 2. b, 3. a, 4. a, 5. c, 6. c, 7. a, 8. a, 9. a, 10. d, 11. b, 12. a, 13. c, 14. d, 15. a, 16. b, 17. a, 18. d, 19. a, 20. a

Quiz – Chapter 26 – Oscillators

1. The term VCO stands for:

- (a) Variable Control Oscillator
- (b) Voltage Controlled Oscillator
- (c) Variable Communication Oscillator
- (d) None of the above

2. Which of the following is a component that you might find changing the frequency of a VCO?

- (a) A varactor or varicap
- (b) A potentiometer
- (c) A variable inductor
- (d) A FET transistor

3. Where might you find a PLL being used?

- (a) In a digital radio receiver
- (b) In an audio amplifier
- (c) In a pocket calculator
- (d) In an electronically controlled door lock

4. Where is the output of a PLL taken from?

- (a) The phase comparator's output
- (b) The frequency multiplier/divider output
- (c) The reference oscillator's output
- (d) The VCO's output

5. Which of the following statements about the 555 timer is true.

- (a) The 555 timer can only be used to make oscillator circuits

- (b) The 555-based oscillator requires more components than its equivalent made from discrete components
- (c) The 555 timer IC is a flexible IC that can be used in many situations, not just as an oscillator.
- (d) The 555 timer is expensive

6. Referring to Figure 26-4 in the book. What is the purpose of C2?

- (a) To set the frequency of the oscillator
- (b) To store energy for use by the IC's output
- (c) To smooth the IC's power supply
- (d) To prevent noise entering the otherwise unused CONT input and affecting the reliability of the circuit.

7. Why doesn't the 555 timer's output load affect the timing of the IC when used as an oscillator?

- (a) The output load does affect the circuit, it should be amplified before driving a load.
- (b) The IC has high current output, so the load current has little effect on the oscillator.
- (c) The DISCH output is buffered and separate from the OUT output used for positive feedback.
- (d) The OUT output is buffered and separate from the DISCH output used for positive feedback.

8. Which of these statements most accurately describes Direct Digital Synthesis (DDS)?

- (a) DDS uses analog electronics to create an analog waveform
- (b) DDS uses analog electronics to create a digital waveform
- (c) DDS uses digital electronics to create an analog waveform
- (d) DDS uses digital electronics to generate a digital waveform

9. Which of these statements about DDS is FALSE?

- (a) DDS is only practical at audio frequencies
- (b) DDS uses digital electronics to create analog waveforms
- (c) DDS hardware is often integrated with a microcontroller
- (d) DDS can be accomplished using a microcontroller and DAC

10. Which of the following factors would you expect to have an effect the frequency of an analog oscillator?

- (a) Temperature sensitivity of resistors
- (b) Resistor value drift over time
- (c) Capacitor value drift over time
- (d) All of the above

11. Which of the following oscillator types is likely to have the most stable frequency?

- (a) an Armstrong oscillator
- (b) a VCO
- (c) a 555 timer IC configured as an oscillator
- (d) Crystal controlled PLL

12. What is the minimum theoretical duty cycle of a 555 IC configured as shown in Figure 26-4 in the book?

- (a) 0%
- (b) 33%
- (c) 50%
- (d) 99%

13. Referring to Figure 26-4 in the book, if R1 is 10k and R2 is 100k and C1 is 10 μ F, what is the approximate frequency of oscillation?

- (a) 0.69 Hz
- (b) 6.9 Hz
- (c) 69 Hz
- (d) 690 Hz

14. Referring to Figure 26-4 in the book, if R1 is 10k and R2 is 100k and C1 is 10 μ F, what is the duty cycle of the oscillator?

- (a) 25.2 %
- (b) 52.4 %

- (c) 73.6 %
- (d) 92.0 %

15. From question 13, if C1 was changed to 1 μ F what would you expect to happen to the frequency?

- (a) The frequency would halve
- (b) The frequency would double
- (c) The frequency would increase by a factor of 10
- (d) The frequency would decrease by a factor of 100

Answers:

1. b, 2. a, 3. a, 4. d, 5. c, 5. d, 6. d, 7. 6, 8. c, 9. a, 10. d, 11. d, 12. c, 13. a, 14. b, 15. c

Quiz – Chapter 27 – Wireless Transmitters and Receivers

1. Which of the following communications modes has a mark component at one carrier frequency and a space component at a different carrier frequency?

- (a) CW
- (b) FSK
- (c) AM
- (d) FM

2. Which of the following communications modes has a mark component in which the carrier is “full-on” and a space component in which the carrier is entirely absent?

- (a) CW
- (b) FSK
- (c) AM
- (d) FM

3. We can demodulate FM signals with

- (a) a discriminator.
- (b) a ratio detector.
- (c) an envelope detector.
- (d) All of the above

4. If we want to demodulate an AM signal, we’ll get the best results with

- (a) a discriminator.
- (b) a ratio detector.
- (c) an envelope detector.
- (d) a product detector.

5. We can accomplish spread-spectrum communications by means of

- (a) ratio detection.
- (b) product detection.
- (c) frequency hopping.
- (d) All of the above

6. Birdies can occur in a

- (a) direct-conversion receiver.
- (b) superheterodyne receiver.
- (c) ratio detector.
- (d) front end with poor dynamic range.

7. The dynamic range specification in a receiver tells us how well the system can handle signals

- (a) in diverse modulation modes.
- (b) over a wide range of frequencies.
- (c) in the presence of high noise levels.
- (d) from extremely weak to extremely strong.

8. Which of the following modes involves breaking a signal down into “pieces” of specific time duration, transmitting the “pieces” in a repeating sequence, and reassembling them back into the original signal at the receiver?

- (a) FSK
- (b) TDM
- (c) AM
- (d) CW

9. Suppose that an RF carrier has a frequency of 830 kHz. We can effectively modulate this carrier with information containing frequency components up to about

- (a) 83.0 Hz.
- (b) 830 Hz.
- (c) 8.30 kHz.
- (d) 83.0 kHz.

10. We might expect to observe a dead spot in communications reception when the direct and reflected waves arrive at the receiving antenna

- (a) with a 0° phase difference.
- (b) with a 180° phase difference.
- (c) with a 90° phase difference.
- (d) in any condition other than phase coincidence.

11. The earth’s atmosphere generally exhibits a decreasing index of refraction, with respect to radio waves, as the altitude above the surface increases. At some radio frequencies, this property gives rise to

- (a) ionospheric reflection.
- (b) troposcatter.
- (c) tropospheric bending.
- (d) auroral propagation.

12. Suppose that we modulate a VHF carrier in the SSB mode with AF data having frequency components up to 20 kHz. What’s the approximate bandwidth of the SSB signal?

- (a) 10 kHz
- (b) 20 kHz
- (c) 40 kHz
- (d) 80 kHz

13. FM broadcast transmissions are generally around the frequency

- (a) 100 kHz
- (b) 1 MHz
- (c) 10 MHz
- (d) 100 MHz

14. We can generate a DSB, suppressed-carrier signal with a

- (a) frequency modulator.
- (b) phase modulator.
- (c) balanced modulator.
- (d) slope modulator.

Schematic 27-1

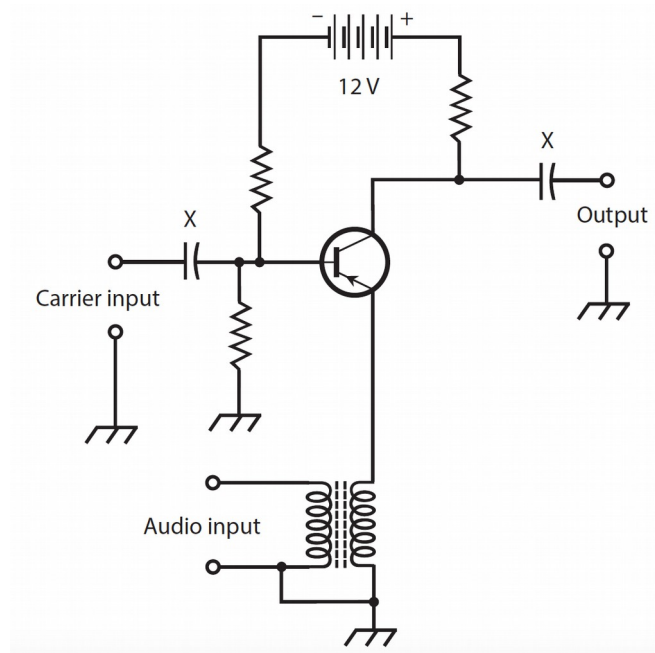

15. Schematic 27-1 illustrates a circuit designed to perform

- (a) ratio detection.
- (b) modulation.
- (c) oscillation.
- (d) product detection.

16. Based on the general knowledge of electronics that we've gained so far in this course, we know that the components marked X in Schematic 27-1

- (a) pass signals but not DC.
- (b) pass DC but not signals.
- (c) ensure that the transistor receives pure DC from the battery.
- (d) limit the current through the transistor E-B and B-C junctions.

17. What appears at the output terminals of the circuit of Schematic 27-1, assuming that we choose the correct component values and operate the system properly?

- (a) An FM signal
- (b) An SSB signal
- (c) A DSB, suppressed-carrier signal
- (d) An AM signal

Schematic 27-2

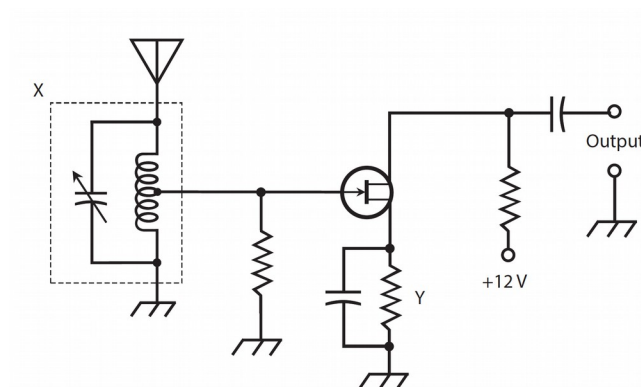

18. Schematic 27-2 shows a weak-signal amplifier that we might find in the front end of a radio communications receiver. What's wrong?

- (a) We should use a P-channel JFET, not an N-channel JFET.
- (b) We should install a blocking capacitor between the gate resistor and the center tap of the inductor.
- (c) We should replace the capacitor at the output terminals with an RF choke.
- (d) We should remove the capacitor between the source and ground.

19. In the circuit of Schematic 27-2, the LC circuit marked X

- (a) optimizes the bias on the JFET.
- (b) prevents strong signals on the desired frequency from overloading the system.
- (c) provides selectivity at the receiver's front end.
- (d) minimizes the S/N ratio.

20. In the circuit of Schematic 27-2, the resistor marked Y

- (a) optimizes the bias on the JFET.
- (b) prevents strong signals from overloading the system.
- (c) provides selectivity.
- (d) minimizes the S/N ratio.

Answers:

1. b, 2. a, 3. d, 4. c, 5. c, 6. b, 7. d, 8. b, 9. d, 10. b, 11. c, 12. b, 13. d, 14. c, 15. b, 16. a, 17. d, 18. b, 19. c, 20. a

Quiz – Chapter 28 – Digital Basics

1. In Boolean algebra, we represent the inclusive logic OR operation as

- (a) multiplication.
- (b) division.
- (c) addition.
- (d) subtraction.

2. The hexadecimal numeral C7 represents the same quantity as the decimal numeral

- (a) 127.
- (b) 199.
- (c) 212.
- (d) 263.

Figure 28-1

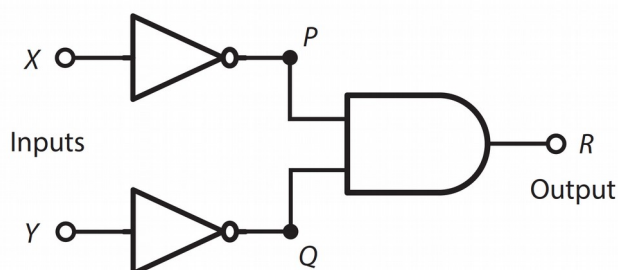

3. Suppose that we place a NOT gate in cascade (that is, in series) with each of the two inputs X and Y of an AND gate, as shown in Fig. 28-1. If $X = 1$ and $Y = 0$, how can we describe the states of the signals at points P and Q ?

- (a) $P = 1$ and $Q = 1$
- (b) $P = 0$ and $Q = 1$
- (c) $P = 1$ and $Q = 0$
- (d) $P = 0$ and $Q = 0$

4. In the situation of Fig. 28-1, under what input conditions will we get logic 1 at the output point R?

- (a) $X = 1$ and $Y = 1$
- (b) $X = 0$ and $Y = 1$
- (c) $X = 1$ and $Y = 0$
- (d) $X = 0$ and $Y = 0$

5. The binary numeral 10101 represents the same quantity as the decimal numeral

- (a) 18.
- (b) 21.
- (c) 29.
- (d) 57.

6. The hexadecimal numeral FF represents the same quantity as the decimal numeral

- (a) 1034.
- (b) 1515.
- (c) 255.
- (d) 194.

7. The decimal numeral 104 translates into the hexadecimal numeral

- (a) 173.
- (b) 11.
- (c) 68.
- (d) 137.

Figure 28-2

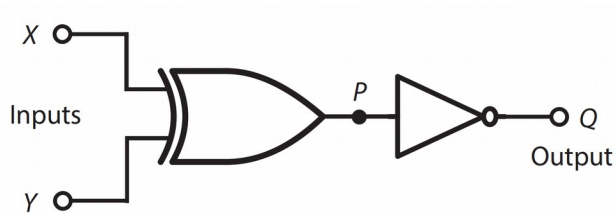

8. Suppose that we place a NOT gate at the output of an XOR gate, as shown in Fig. 28-2, and then we operate the combination of gates as a “black box.” Under what input conditions X and Y will we get a low state at the output point Q?

- (a) Only when $X = 0$ and $Y = 0$
- (b) Only when $X = 1$ and $Y = 1$
- (c) Whenever $X = Y$ (X and Y have the same state)
- (d) Whenever $X \neq Y$ (X and Y have opposite states)

9. Under what input conditions X and Y will we get a high state at the output point Q in the “black box” of Fig. 28-2?

- (a) Only when $X = 0$ and $Y = 0$
- (b) Only when $X = 1$ and $Y = 1$
- (c) Whenever $X = Y$
- (d) Whenever $X \neq Y$

10. The second digit from the left in an eight-digit binary numeral carries a decimal value equal to a multiple of

- (a) 64.

- (b) 128.
- (c) 256.
- (d) 512.

11. The decimal numeral 35 translates into the hexadecimal numeral

- (a) B2.
- (b) 2A.
- (c) AB.
- (d) 23.

12. When both inputs of an R-S flip-flop are high, the output states are

- (a) unpredictable.
- (b) both high.
- (c) both low.
- (d) opposite.

Figure 28-3

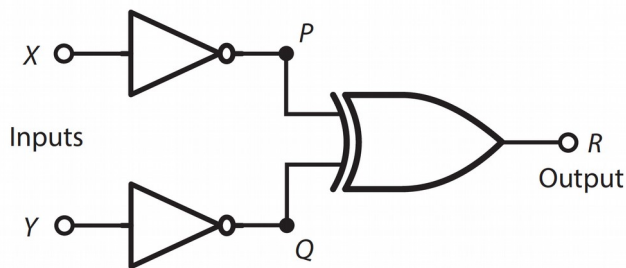

13. Suppose that we place a NOT gate in cascade with each of the two inputs X and Y of an XOR gate, as shown in Fig. 28-3. Under what input conditions will we get logic 1 at the output point R ?

- (a) Only when $X = 1$ and $Y = 1$
- (b) Only when $X = 0$ and $Y = 0$
- (c) Whenever $X = Y$
- (d) Whenever $X \neq Y$

14. In the circuit of Fig. 28-3, under what input conditions will we get logic 0 at the output point R ?

- (a) Only when $X = 1$ and $Y = 1$
- (b) Only when $X = 0$ and $Y = 0$
- (c) Whenever $X = Y$
- (d) Whenever $X \neq Y$

15. In the hexadecimal numeration system, what follows 999?

- (a) 1000
- (b) 99A
- (c) A000
- (d) A99

16. Digital signal processing can be used for

- (a) tone-controls on hifi systems
- (b) noise reduction in audio systems
- (c) filtering of audio signals
- (d) All of the above

17. The largest decimal value that we can represent as an eight-digit binary numeral is

- (a) 511.

- (b) 255.
- (c) 127.
- (d) 63.

18. To maximize the amount of useful information conveyed in a given time without increasing the actual number of characters or symbols sent, we can employ

- (a) D/A conversion.
- (b) A /D conversion.
- (c) data compression.
- (d) data acceleration.

19. If both of the inputs to a two-input NAND gate equal logic 0, the output state is

- (a) low.
- (b) high.
- (c) unpredictable and unstable.
- (d) a function of the previous states.

20. What do we call the number of times per second that a digital signal changes from high to low or vice versa?

- (a) Baud
- (b) Bits per second
- (c) Characters per second
- (d) Conversion rate

Answers:

1. c, 2. b, 3. b, 4. d, 5. b, 6. c, 7. c, 8. d, 9. c, 10. a, 11. d, 12. a, 13. d, 14. c, 15. b, 16. d, 17. b, 18. c, 19. b, 20. a

Test – Part 3

1. When you design a power supply that uses rectifier diodes, you must make sure that each diode can handle

- (a) at least the expected average DC forward current.
- (b) at least half again the expected average DC forward current.
- (c) no more than 60 Hz.
- (d) at least 100 V RMS.
- (e) transients caused by lightning striking a nearby power line.

2. A crystal set radio receiver comprises an antenna, a detector, a headset shunted by a capacitor, and

- (a) an LC circuit.
- (b) an amplifier.
- (c) an oscillator.
- (d) a mixer.
- (e) all of the above

3. If you want current to flow between the source and drain of an N-channel JFET for the entire input cycle, you must make sure that

- (a) the gate-source junction remains reverse-biased, but at a voltage that never exceeds the pinchoff value during any part of the cycle.
- (b) the gate-source junction remains forward-biased, but at a voltage that never exceeds the pinchoff value during any part of the cycle.
- (c) the gate-source junction remains reverse-biased, but at a voltage that never falls below the pinchoff value during any part of the cycle.
- (d) the gate-source junction remains forward-biased, but at a voltage that never falls below the pinchoff value during any part of the cycle.

(e) the gate-source junction remains zero-biased.

4. As you increase the negative DC gate voltage to a P-channel JFET while holding the negative DC drain voltage constant, what happens to the drain current, assuming that you apply no input signal?

- (a) The drain current rises and eventually levels off when the gate-drain junction approaches a state of saturation.
- (b) The drain current decreases because the channel narrows, reducing its conductance.
- (c) The drain current increases because the source current increases, increasing the effective conductance of the channel.
- (d) The drain current remains the same because the channel width remains constant.
- (e) The drain current decreases because current bleeds off into the gate from the channel.

5. In the scenario of Question 4, suppose that you keep increasing the negative DC gate voltage while leaving the negative DC drain voltage constant. What will happen to the drain current in the absence of an input signal?

- (a) The drain current will keep going down and approach zero because more and more of the channel current will bleed off through the gate.
- (b) The drain current will remain constant until, at a certain point, the extreme negative gate voltage will destroy the device.
- (c) The drain current will increase as the channel conductance improves, all the way up to the point at which the extreme negative gate voltage destroys the device.
- (d) The channel current will drop to zero and then reverse direction.
- (e) The drain current will attain its maximum value for the particular DC drain voltage that you apply.

6. If you increase by tenfold the power dissipated by a load that has no reactance, you get

- (a) 3 dB gain.
- (b) 6 dB gain.
- (c) 10 dB gain.
- (d) 20 dB gain.
- (e) 100 dB gain.

7. If you increase by tenfold the voltage across a load that has no reactance, you get

- (a) 3 dB gain.
- (b) 6 dB gain.
- (c) 10 dB gain.
- (d) 20 dB gain.
- (e) 100 dB gain.

8. In a depletion-mode JFET, DC gate bias of the appropriate polarity

- (a) keeps the input signal from leaking through to the source.
- (b) prevents destruction of the device by electrostatic discharge.
- (c) keeps the device from oscillating.
- (d) constricts the channel between the source and drain.
- (e) forms a channel between the source and drain.

9. If you double the RMS current through a load with a purely resistive impedance, you get a gain of

- (a) 3 dB.
- (b) 4 dB.
- (c) 6 dB.
- (d) 8 dB.
- (e) 12 dB.

10. How does the phase of the AC output signal compare with the phase of the AC input signal in a class-A, common-emitter, bipolar-transistor amplifier?

- (a) The output and input waves coincide in phase.
- (b) The output wave leads the input wave by 90° .
- (c) The output wave lags the input wave by 90° .
- (d) The output and input waves oppose each other in phase.
- (e) In an NPN device, the output wave leads the input wave by 90° ; in a PNP device, the output wave lags the input wave by 90° .

Figure Test 3-1.

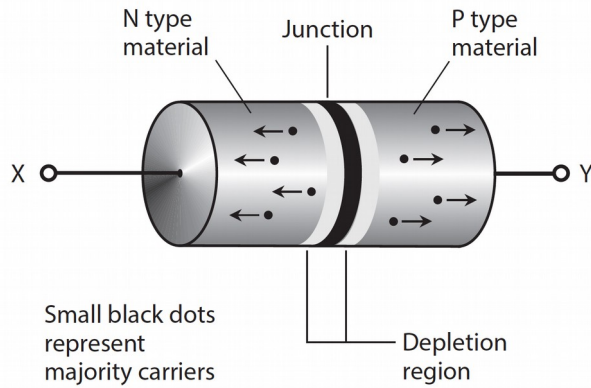

11. Figure Test 3-1 shows the situation inside a semiconductor diode under certain conditions. The small black dots represent majority carriers on either side of the P-N junction. The presence of a depletion region suggests

- (a) forward bias.
- (b) reverse bias.
- (c) zero bias.
- (d) that the diode is intended for switching.
- (e) that the diode is intended for rectification.

12. In the scenario of Fig. Test 3-1, the particles moving toward point X are

- (a) protons.
- (b) neutrons.
- (c) electrons.
- (d) positrons.
- (e) holes.

13. A PIN diode works best as a

- (a) rectifier.
- (b) detector.
- (c) mixer.
- (d) frequency multiplier.
- (e) high-speed switch.

Figure Test 3-2

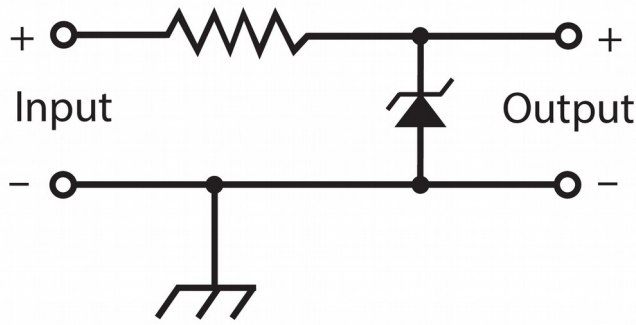

14. Figure Test 3-2 shows a circuit that's intended for the output of an AC-to-DC power supply.

The resistor

- (a) limits the output voltage.
- (b) limits the current that the Zener diode must handle.
- (c) maximizes the output voltage.
- (d) maximizes the current that the supply can deliver.
- (e) keeps the output power under control.

15. A class-B bipolar-transistor power amplifier operates with an efficiency of 50%. We measure the RMS output power as 70 W across a load devoid of reactance. What's the DC collector input power?

- (a) 35 W
- (b) 49 W
- (c) 99 W
- (d) 140 W
- (e) We need more information to figure it out.

16. Which of these amplifier types is most power efficient? b

- (a) A class A bipolar transistor amplifier
- (b) A class D amplifier
- (c) A push-pull amplifier IC
- (d) A class B bipolar transistor amplifier
- (e) A class B J-FET transistor amplifier

17. In an IC, component density correlates directly with

- (a) operating speed.
- (b) power output.
- (c) voltage rating.
- (d) current drain.
- (e) All of the above

18. If you input signals at 6.0 MHz and 2.5 MHz to a mixer, at which of the following frequencies should you not expect to get any output?

- (a) 8.5 MHz
- (b) 3.5 MHz
- (c) 6.0 MHz
- (d) 15.0 MHz
- (e) 2.5 MHz

19. What's a major advantage of frequency-shift keying (FSK) over simple on /off keying such as Morse code?

- (a) Narrower bandwidth
- (b) Higher speed
- (c) Greater accuracy
- (d) Improved frequency stability

(e) Reduced harmonic emission

20. In which of the following systems could you use a vacuum tube instead of a transistor?

- (a) Hi-fi audio power amplifier
- (b) Radio-frequency (RF) oscillator
- (c) RF power amplifier
- (d) Weak-signal RF amplifier
- (e) All of the above

Figure Test 3-3

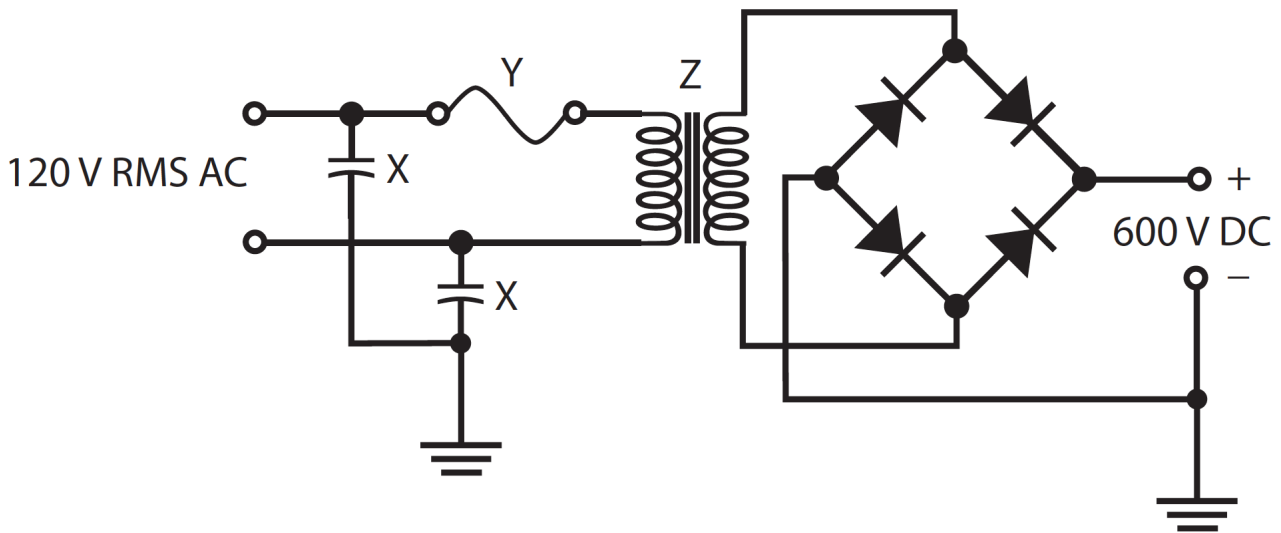

21. Figure Test 3-3 is a diagram of a power supply designed to produce high-voltage DC. It lacks an essential circuit. What is it, and what should it do?

- (a) A filter to get pure DC at the output
- (b) A capacitor to regulate the output voltage
- (c) A resistor to limit the output current
- (d) A diode to double the ripple frequency
- (e) A coil to stabilize the output power

22. What's the purpose of the components marked X in Fig. Test 3-3?

- (a) Stabilize the input voltage
- (b) Limit the power that the device consumes
- (c) Keep the input terminals from shorting to ground
- (d) Ensure that the input is a pure AC sine wave
- (e) None of the above

23. In Fig. Test 3-3, what's the component represented by the symbol marked Y?

- (a) A current limiter
- (b) A rectifier
- (c) An AC line filter
- (d) An incandescent lamp
- (e) A fuse

24. In Fig. Test 3-3, what's the component represented by the symbol marked Z?

- (a) An isolation transformer
- (b) A step-up transformer
- (c) A wave-smoothing coil

- (d) A ripple filter
- (e) A transient suppressor

Figure 3-4

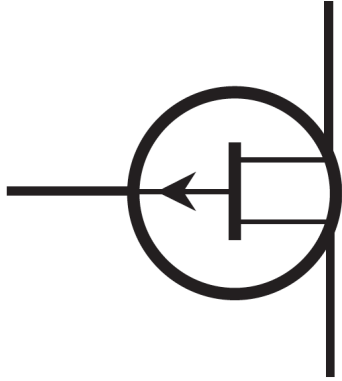

25. Figure Test 3-4 shows the schematic symbol for
- (a) an NPN bipolar transistor.
 - (b) a PNP bipolar transistor.
 - (c) an N-channel JFET.
 - (d) a P-channel JFET.
 - (e) an enhancement-mode MOSFET.
26. In Fig. Test 3-4, what's the electrode represented by the line with the arrow?
- (a) The gate
 - (b) The emitter
 - (c) The source
 - (d) The collector
 - (e) The base
27. Which of the following components will you find in an optoisolator?
- (a) Photodiode
 - (b) Bipolar transistor
 - (c) Field-effect transistor (FET)
 - (d) Capacitor
 - (e) Digital integrated circuit (IC)
28. You bias a JFET beyond pinchoff (under no-input-signal conditions) for use as an RF power amplifier. It takes a fairly strong input signal to produce any output. Even then, channel current flows for less than half the cycle. You have a
- (a) class-A amplifier.
 - (b) class-AB₁ amplifier.
 - (c) class-AB₂ amplifier.
 - (d) class-B amplifier.
 - (e) class-C amplifier.
29. Imagine that over a small range, an increase in the voltage across a component causes the current to decrease. This is an example of
- (a) negative resistance.
 - (b) parasitic conduction.
 - (c) current-reversal effect.

- (d) avalanche effect.
- (e) None of the above, because such a situation can never occur.

Figure Test 3-5

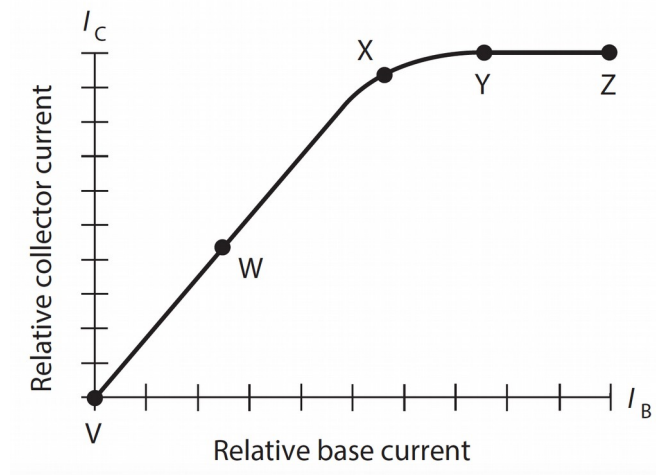

30. Figure Test 3-5 shows how the collector current varies as a function of the base current for a bipolar transistor under no-signal conditions. If you want to use the device as a class-B amplifier, at which point should you bias it?

- (a) Point V
- (b) Point W
- (c) Point X
- (d) Point Y
- (e) Point Z

31. In Fig. Test 3-5, point V portrays

- (a) linear bias.
- (b) cutoff.
- (c) zero bias.
- (d) saturation.
- (e) pinchoff.

32. You can construct a push-pull amplifier with two identical JFETs, connecting the gates in phase opposition and connecting the drains

- (a) in phase coincidence.
- (b) 30° out of phase.
- (c) 60° out of phase.
- (d) 90° out of phase.
- (e) in phase opposition as well.

33. In an FM signal, the extent to which the instantaneous signal amplitude varies is called

- (a) zero, because it remains constant!
- (b) the modulation index.
- (c) the amplitude deviation.
- (d) the amplitude fluctuation.
- (e) the amplitude differential.

34. If we want a diode to completely block current in the reverse direction, we must ensure that

- (a) the N type material has a more positive voltage than the P type material, and the peak applied voltage remains below the avalanche threshold.
- (b) the N type material has a more negative voltage than the P type material, and the peak applied voltage remains below the avalanche threshold.

- (c) the N type material has a more positive voltage than the P type material, and the peak applied voltage exceeds the avalanche threshold.
- (d) the N type material has a more negative voltage than the P type material, and the peak applied voltage exceeds the avalanche threshold.
- (e) the peak applied voltage never exceeds the alpha cutoff value.

Figure Test 3-6

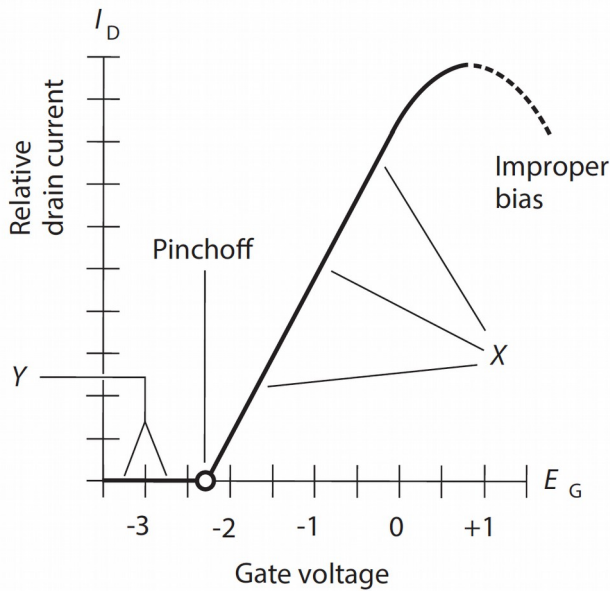

35. Figure Test 3-6 shows how the gate voltage affects the drain current in a typical JFET. If you bias the device near the middle of the range marked X without inputting any signal, you have conditions good for
- (a) class-A amplification.
 - (b) class-B amplification.
 - (c) class-C amplification.
 - (d) class-D amplification.
 - (e) class-E amplification.

36. In most dielectric materials, radio waves travel at less than the speed of light, so the wavelength is shorter than it would be at the same frequency in air or a vacuum. For any given dielectric, the ratio of the shortened wavelength to the wavelength in air or a vacuum is called its
- (a) wavelength ratio.
 - (b) speed ratio.
 - (c) velocity factor.
 - (d) propagation factor.
 - (e) frequency factor.

Figure Test 3-7

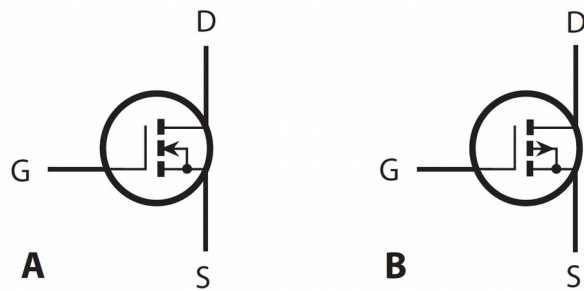

37. Figure Test 3-7 shows the schematic symbols for
- N-channel (at A) and P-channel (at B) depletion-mode JFETs.
 - N-channel and P-channel enhancement-mode JFETs.
 - N-channel and P-channel depletion-mode MOSFETs.
 - N-channel and P-channel enhancement-mode MOSFETs.
 - nothing that we've discussed in this book, at least not yet.
38. The devices symbolized in Fig. Test 3-7 have
- extremely high input impedances.
 - extremely low input impedances.
 - excellent linearity but no way to produce any gain.
 - high bias voltage requirements.
 - no known characteristic; neither has appeared in this book, at least not yet.
39. What's the decimal value of the quantity represented by the binary numeral 11011?
- 18
 - 22
 - 27
 - 31
 - 37
40. When you design and build a power supply, you can best minimize the risk of transient-related diode failure by
- inserting a timed switch that will reduce the AC input voltage for a few seconds after the transient occurs.
 - using RF diodes instead of rectifier diodes.
 - connecting a small-value resistor in parallel with each diode.
 - placing a transient suppressor in the AC input line.
 - using a transformer that can handle extremely high current.
41. How can we render the decimal quantity 45 in binary terms?
- 101101
 - 100100
 - 110001
 - 100011
 - 111011

Figure Test 3-8

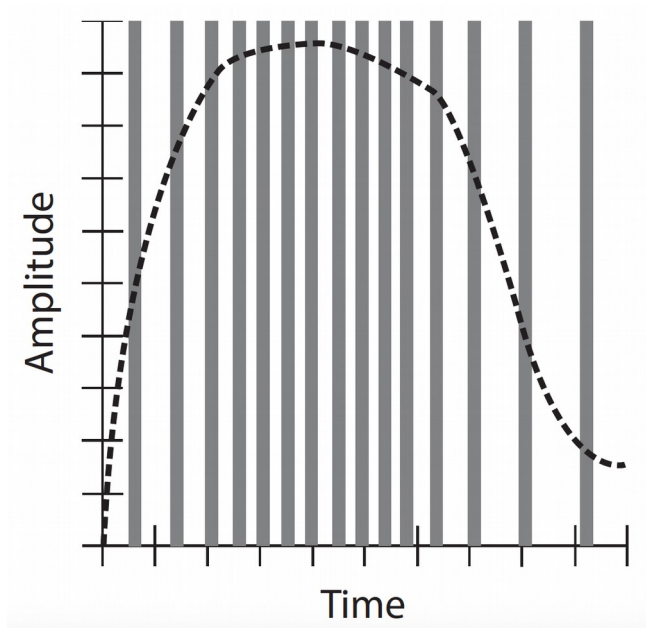

42. Figure Test 3-8 is a time-domain graph illustrating the principle of

- (a) pulse-code modulation.
- (b) pulse-amplitude modulation.
- (c) pulse-duration modulation.
- (d) pulse-interval modulation.
- (e) pulse-width modulation.

43. You can increase the sensitivity of your HF radio receiver by

- (a) using a squelch to silence the receiver when no signal comes in.
- (b) placing a preamplifier between the antenna and the front end.
- (c) reducing the voltage of the receiver's power supply or battery.
- (d) incorporating a balanced modulator to cancel out noise.
- (e) adding a notch filter to increase the IF bandwidth.

44. For class-C power amplification, you should, under no-signal conditions, bias a bipolar transistor

- (a) so drain current never flows, no matter how strong the input signal gets.
- (b) somewhat beyond cutoff.
- (c) exactly at cutoff.
- (d) such that steady drain current flows.
- (e) to saturation.

45. Which of the following components does a 555 Timer IC contain?

- (a) A voltage divider
- (b) A comparator
- (c) A flip-flop
- (d) A voltage divider
- (e) All of the above

46. Which of these factors is unlikely to affect the frequency stability of an amplifier? d

- (a) Movement in the coil of an inductor
- (b) Changes to a capacitor's value over time
- (c) The temperature stability of a fixed resistor
- (d) The tolerance of a fixed resistor
- (e) All of these factors could affect frequency stability

47. In a class-A JFET amplifier, a small change in the instantaneous gate voltage should produce

- (a) a large change in the instantaneous drain voltage.
- (b) an even smaller change in the instantaneous source voltage.
- (c) a large change in the instantaneous channel current.
- (d) an equivalent change in the instantaneous channel voltage.
- (e) no change in the instantaneous channel current.

48. What is the decimal value of the binary number 1111111

- (a) 127
- (b) 128
- (c) 133
- (d) 111
- (e) 100

49. In the hexadecimal numeration system, what follows A as you count upward?

- (a) Nothing; that system has no digit A.
- (b) B
- (c) C
- (d) D
- (e) 10

50. What will the output voltage be of a three input NAND gate operating at 5V, where all three inputs are 5V.

- (a) 0V
- (b) 1V
- (c) 5V
- (d) 15V
- (e) We need to know more about the circuit

1. b, 2. a, 3. a, 4. e, 5. a, 6. c, 7. d, 8. d, 9. c, 10. d, 11. b, 12. c, 13. e, 14. b, 15. d, 16. b, 17. a, 18. d, 19. c, 20. e, 21. a, 22. e, 23. e, 24. b, 25. d, 26. a, 27. a, 28. e, 29. a, 30. a, 31. b, 32. e, 33. a, 34. a, 35. a, 36. c, 37. d, 38. a, 39. c, 40. d, 41. a, 42. d, 43. b, 44. b, 45. e, 46. d, 47. c, 48. a, 49. b, 50. a